

TECHNICAL SPECIFICATIONS

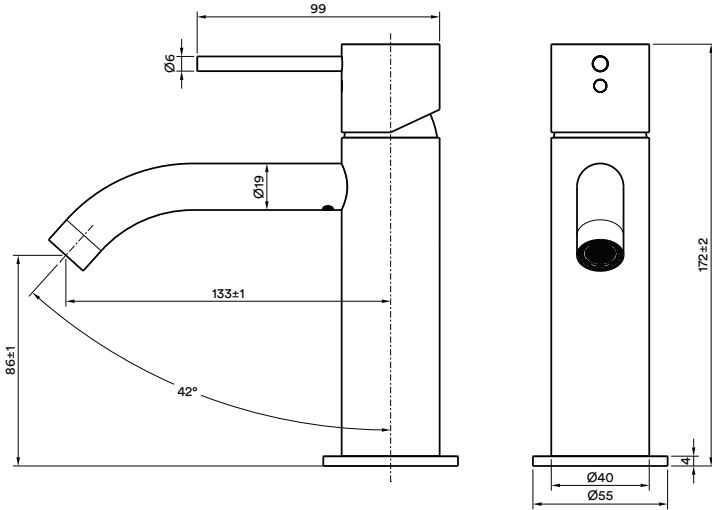

PRODUCT



STEEL

MIX - SS - 003

Basin Mixer

DETAILED ASSEMBLY

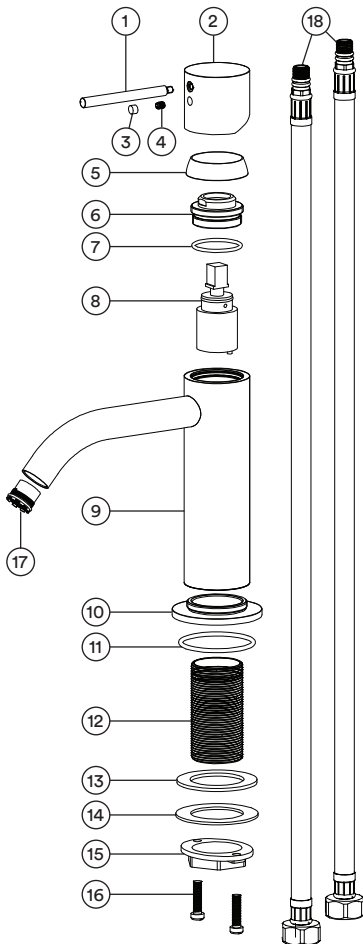

No	Description	Qty	Material
1	Pin Handle	1	316L
2	Handle	1	316L
3	Rubber Plug	1	NBR
4	Screw	1	316L
5	Cap	1	316L
6	Cartridge Cap	1	316L
7	O-Ring	1	NBR
8	Cartridge (25D-1)	1	Assembly
9	Faucet Body	1	316L
10	Base	1	316L
11	O-Ring	1	NBR
12	Shank	1	SUS-304
13	Rubber Gasket	1	NBR
14	SS Gasket	1	SUS-304
15	Lock Nut	1	SUS-304
16	Screw	2	SUS-304
17	Aerator	1	ABS
18	Inlet Hose	2	Assembly

FEATURES

- 15 year warranty.
- 316 stainless steel.
- European cartridge.
- Flow rate: 4.5 Litres per minute @ 3 bar pressure.



WARRANTY

Refer to joansa.co.za for warranty terms & conditions.

CARE

Preparation:

Apply copper slip lubricant to prevent seizing of threaded fasteners.

Cleaning:

- Remove dirt using clean water and a soft cotton cloth.
- Clean the stainless steel surface with:
 - Gentle liquid detergent.
 - Colourless glass cleaner.
 - Non-abrasive polishes.
- Dry and remove all cleaning material with a soft cotton cloth.

CERTIFICATION

JASWIC APPROVED.
SABS TESTED & APPROVED.

FLOW RATE

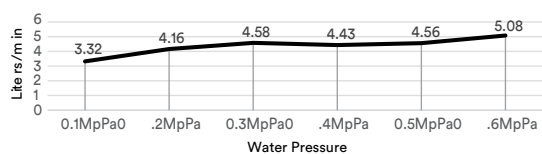

Joan

Stainless Steel
with a conscience

+27 (021) 510 0489
30 Royal Road, Maitland,
Cape Town. 7405. South Africa