

## TECHNICAL SPECIFICATIONS

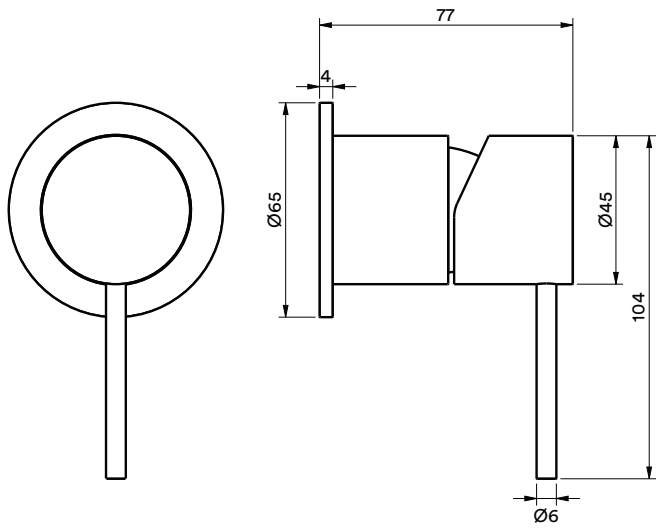

## PRODUCT



# STEEL

## FIN - SS - 002

Finish Set Single Mixer

## DETAILED ASSEMBLY

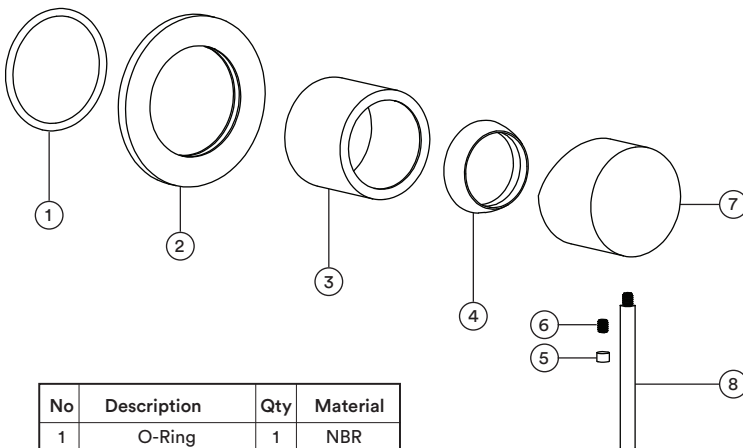

No	Description	Qty	Material
1	O-Ring	1	NBR
2	Base	1	316L
3	Cartridge Cover	1	316L
4	Cartridge Nut	1	316L
5	Rubber Plug	1	NBR
6	Screw	1	SUS-304L
7	Mixer Handle	1	316L
8	Mixer Handlebar	1	316L

## FEATURES

- 15 year warranty.
- 316 stainless steel.
- European cartridge.
- Flow rate: 23 Litres per minute @ 3 bar pressure.



## WARRANTY

Refer to [joansa.co.za](http://joansa.co.za) for warranty terms & conditions.

## CARE

### Preparation:

Apply copper slip lubricant to prevent seizing of threaded fasteners.

### Cleaning:

- Remove dirt using clean water and a soft cotton cloth.
- Clean the stainless steel surface with:
  - Gentle liquid detergent.
  - Colourless glass cleaner.
  - Non-abrasive polishes.
- Dry and remove all cleaning material with a soft cotton cloth.

## CERTIFICATION

JASWIC APPROVED.  
SABS TESTED & APPROVED.

## FLOW RATE

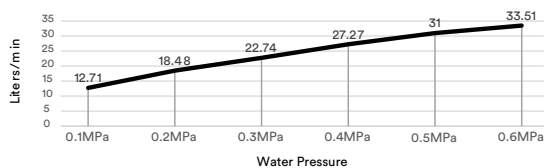

# Joan

Stainless Steel  
with a conscience

+27 (021) 510 0489  
30 Royal Road, Maitland,  
Cape Town. 7405. South Africa