

STEEL

CON - SS - 003

Concealed Body for Freestanding Bath Mixer

TECHNICAL SPECIFICATIONS

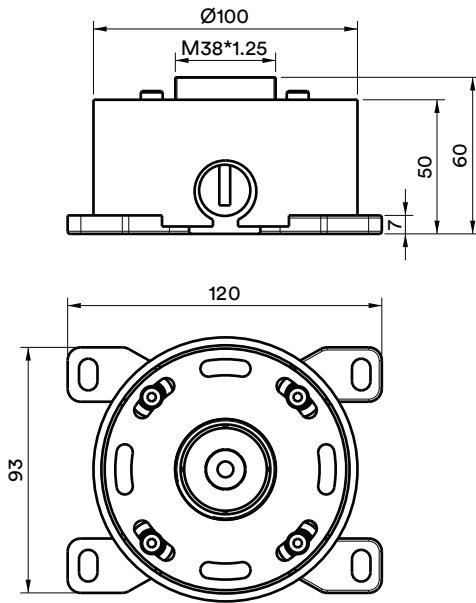

PRODUCT



DETAILED ASSEMBLY

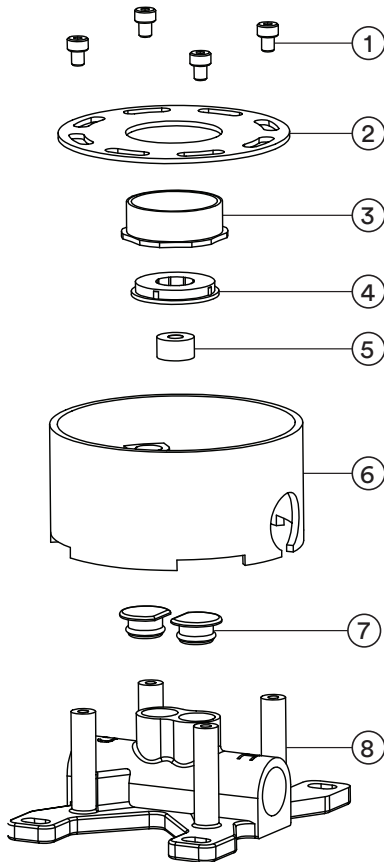

No	Description	Qty	Material
1	Screw	4	SUS-304
2	Cover Plate	1	SUS-304
3	Connector	1	SUS-304
4	Level Holder	1	ABS
5	Level	1	Assembly
6	Embedded Box	1	ABS
7	Plug	2	ABS
8	Base Body	1	SUS-304

FEATURES

- 15 year warranty.
- 304 stainless steel.
- Flow rate: 20.5 Litres per minute @ 3 bar pressure.
- Flow rate is regulated by the mixer used.

WARRANTY

Refer to joansa.co.za for warranty terms & conditions.

CARE

Preparation:

Apply copper slip lubricant to prevent seizing of threaded fasteners.

Cleaning:

- Remove dirt using clean water and a soft cotton cloth.
- Clean the stainless steel surface with:
 - Gentle liquid detergent.
 - Colourless glass cleaner.
 - Non-abrasive polishes.
- Dry and remove all cleaning material with a soft cotton cloth.

CERTIFICATION

JASWIC APPROVED.
SABS TESTED & APPROVED.

Joan
Stainless Steel
with a conscience

+27 (021) 510 0489
30 Royal Road, Maitland,
Cape Town. 7405. South Africa